

WB80

WALL BOX FOR PS80

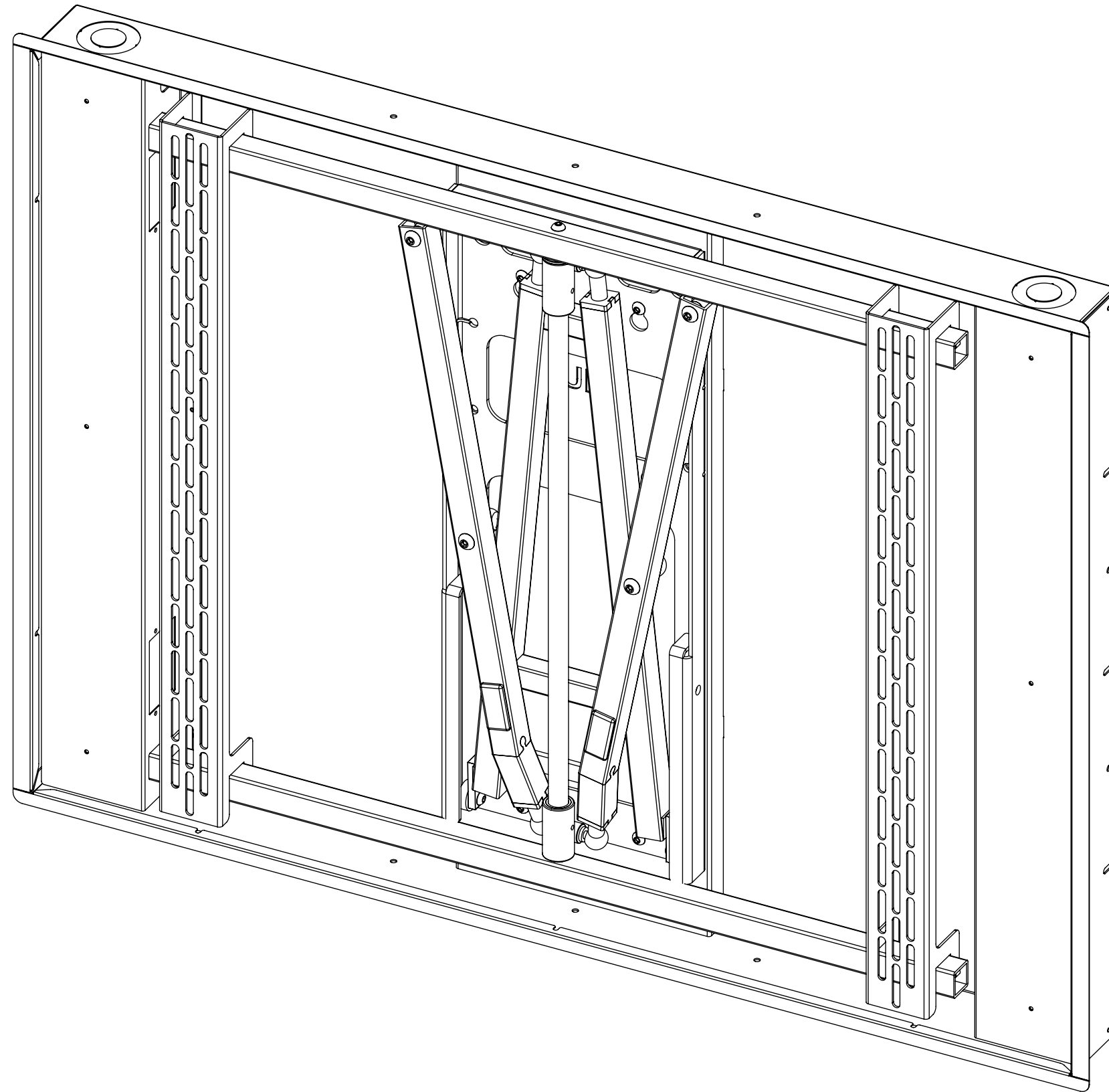

future automation



WB80

WALL BOX FOR PS80



future automation

SPECIFICATION	MEASUREMENTS
Product Dimensions	1203mm (47.5") x 887mm (35") x 97mm (4")
Screen Size	60" - 90"
PS Bracket Compatibility	PS80
Packaging Dimensions	1330 x 1070 x 240mm (52.3 x 42.1 x 9.4")
Shipping Weight	36kg (79lbs)
Product Options / Features	Custom RAL paint finishes
Package Contents	Wall Box and accessories
Marine Suitable	No

WB80 WALL BOX FOR PS80

CABLE ROUTING

Run the cables up to either top corner of the wall bracket, loop over and run down the out side of the scissor leg as shown with the red line. Secure the cables using cable ties and make sure to allow slack at moving points. Knock out the relevant cable knock outs to pass the cable through the wall box into the wall cavity.

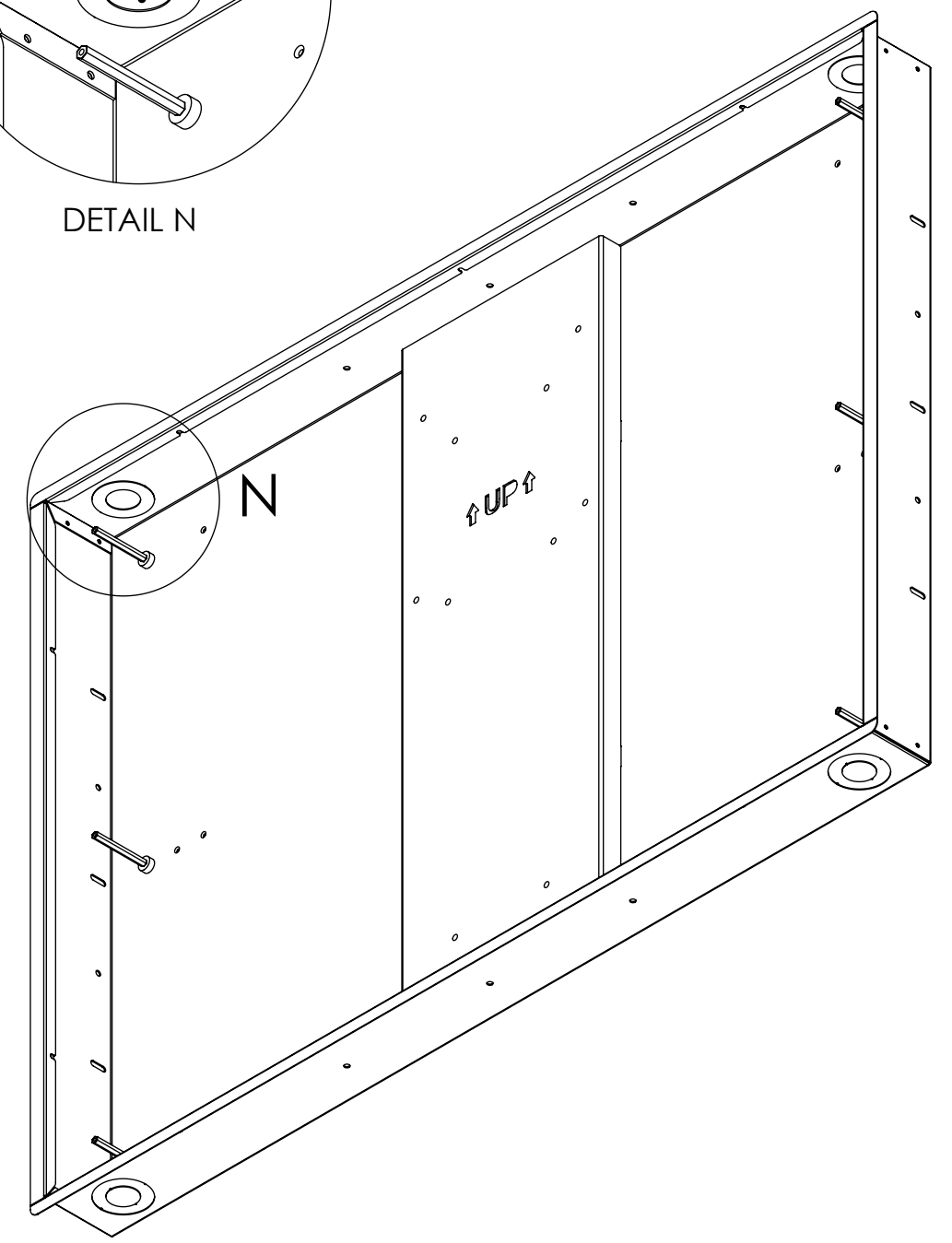
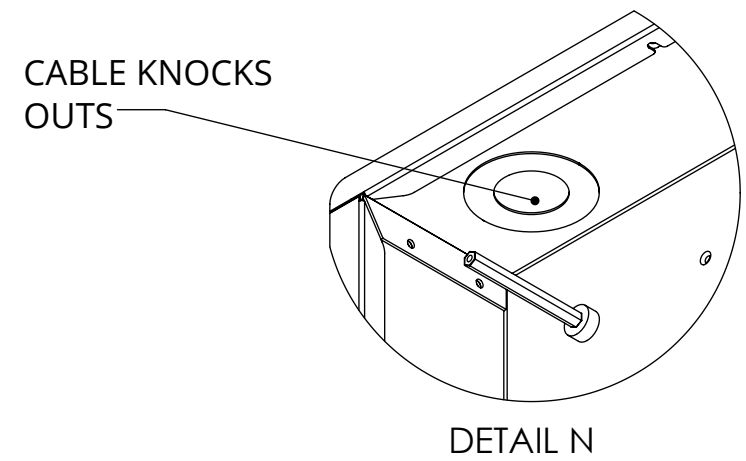
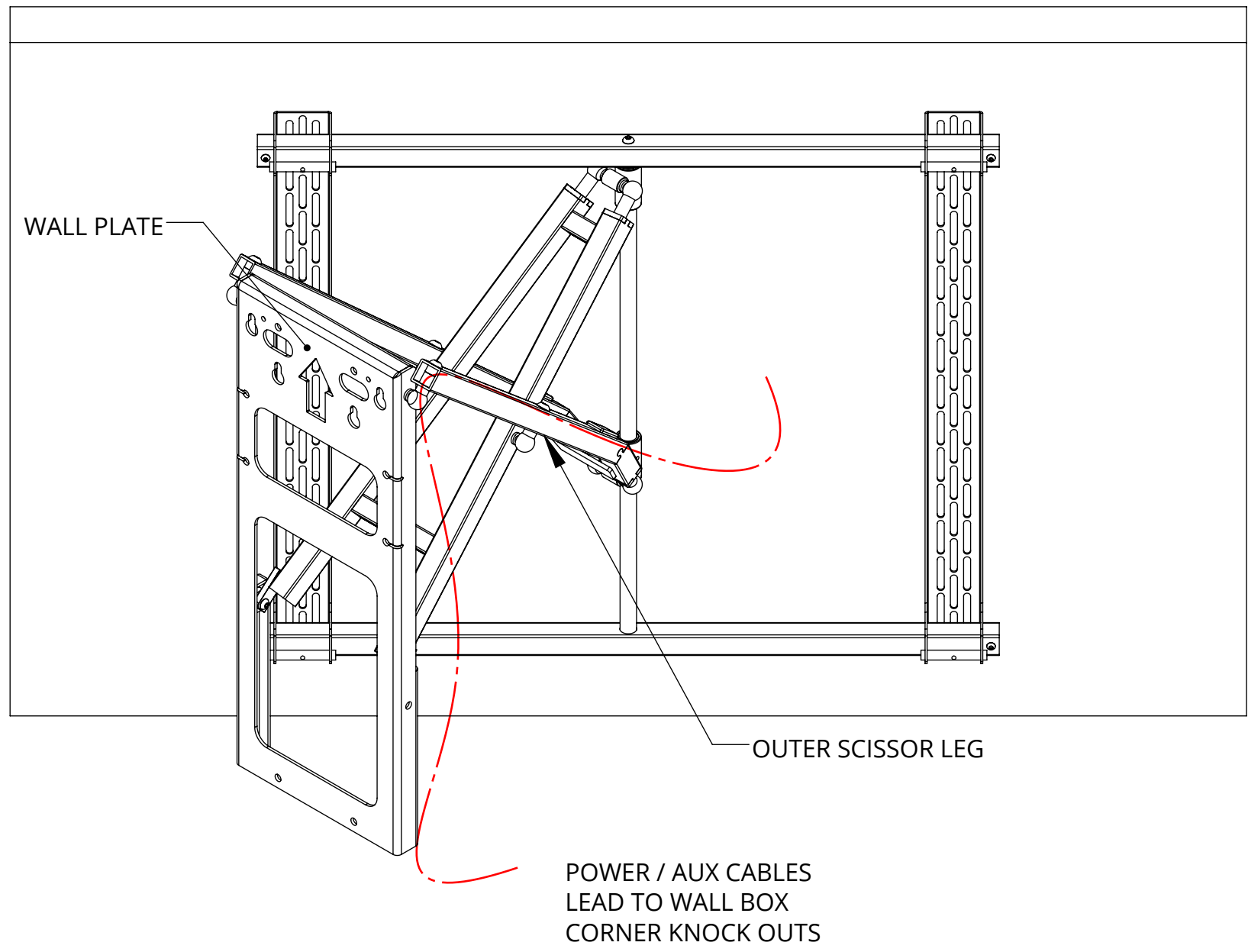

WB80

WALL BOX FOR PS80

WALL BOX MOUNTING DIMENSIONS

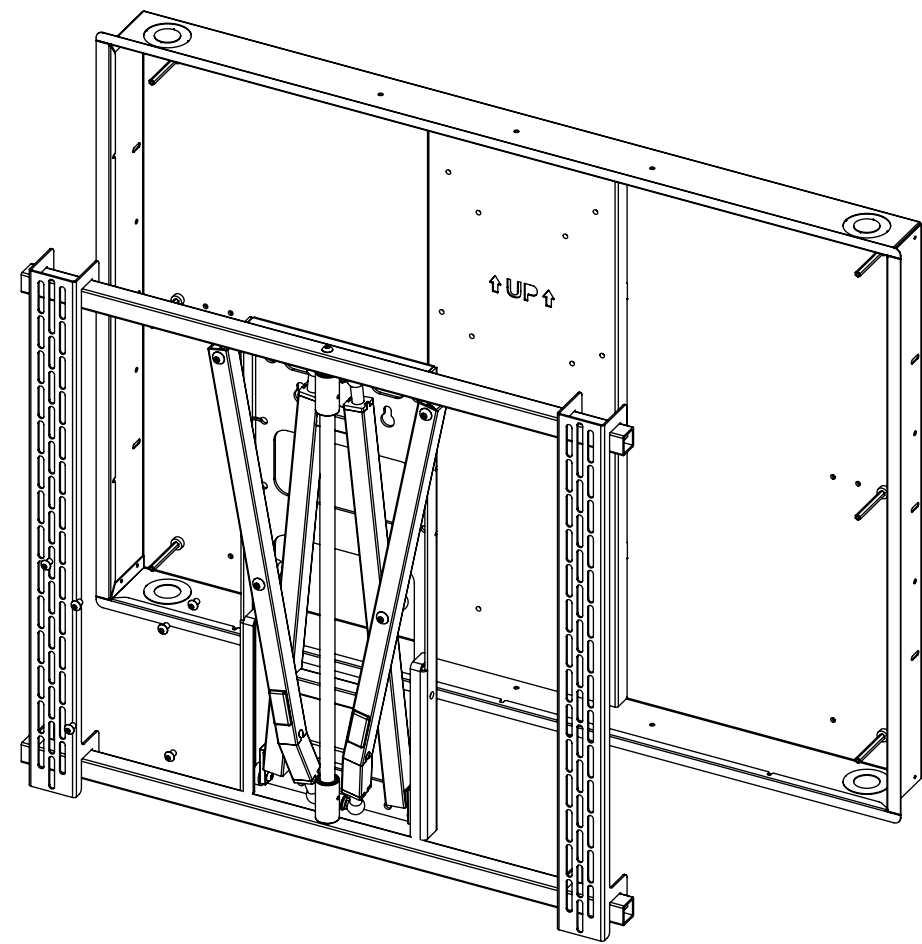
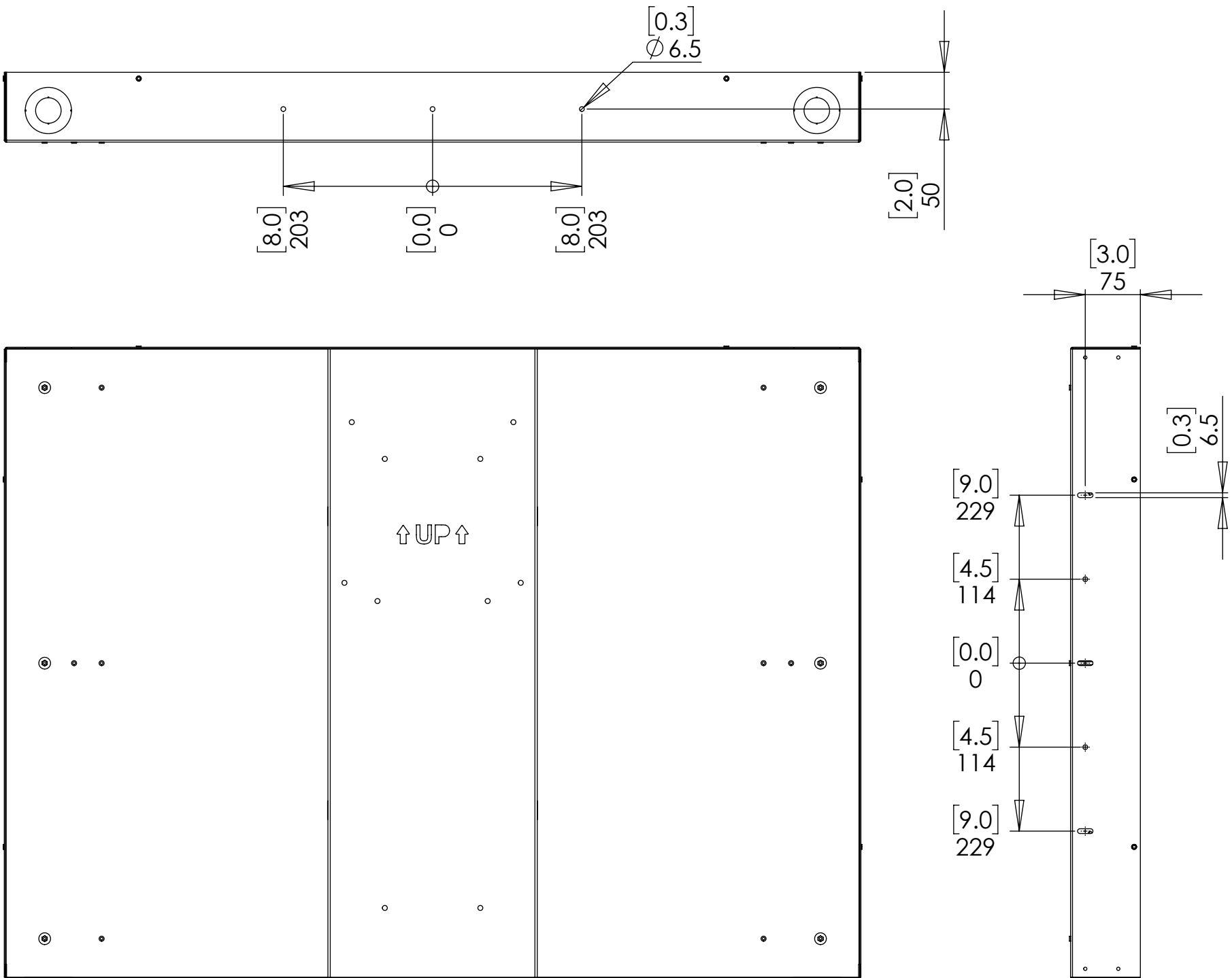

REMOVE THE PS BRACKET FROM THE WALL BOX BY REMOVING THE BOLTS IN THE BACK MOUNT PLATE AS SHOWN, THIS WILL MAKE MOUNTING THE WALL BOX INTO THE WALL A LOT EASIER.

WB80

WALL BOX FOR PS80

GENERAL DIMENSIONS

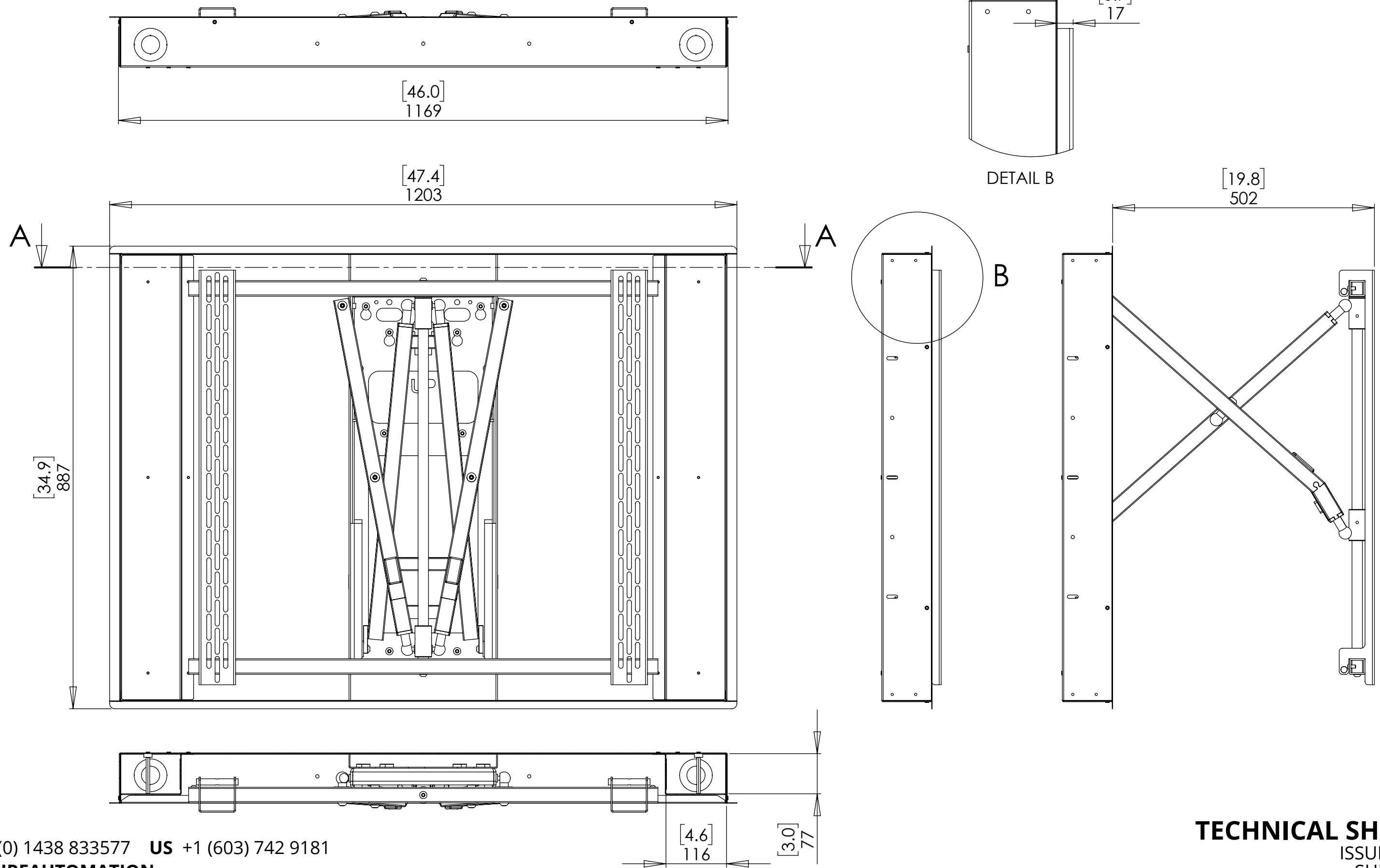

WB80 WALL BOX FOR PS80

SWIVEL ANGLES

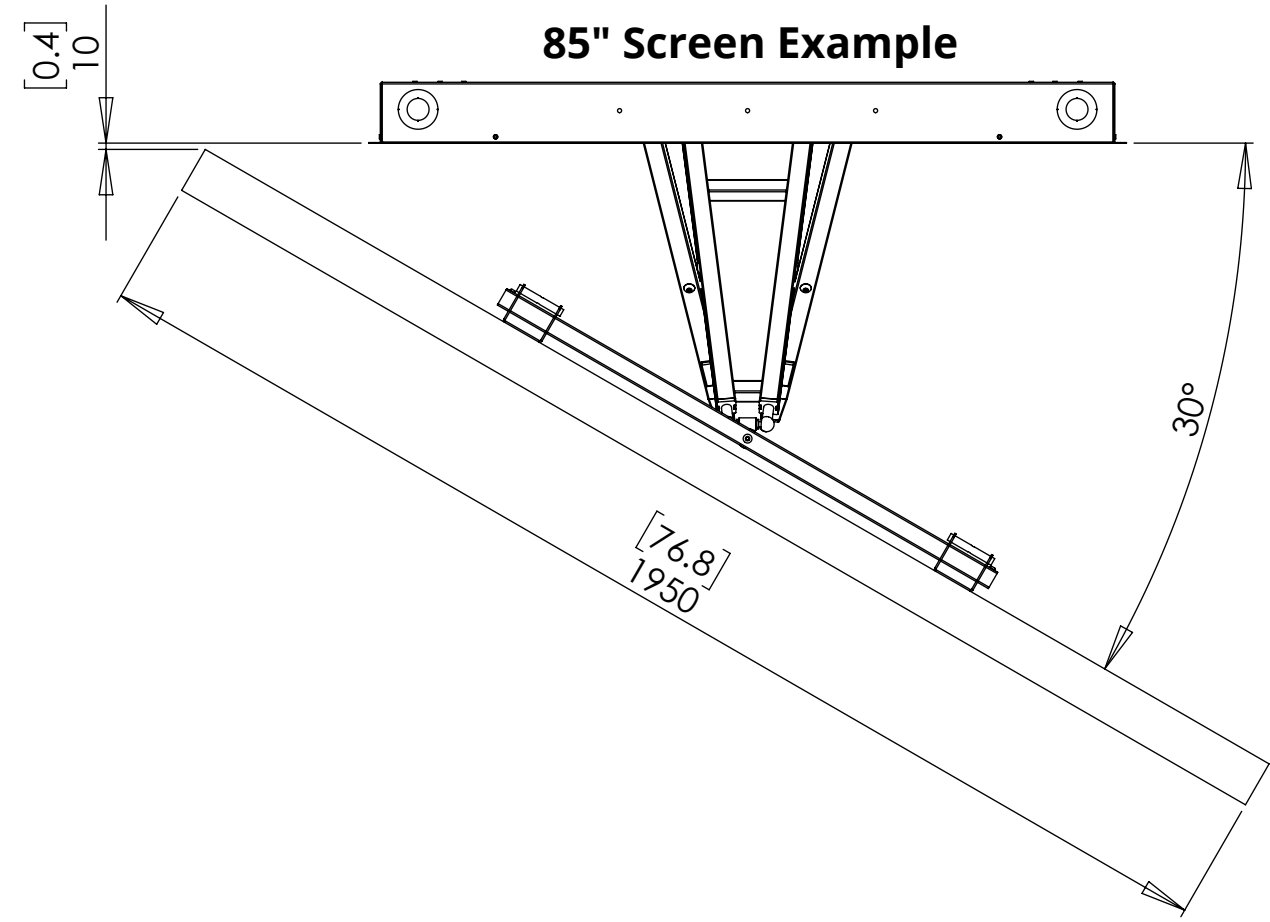
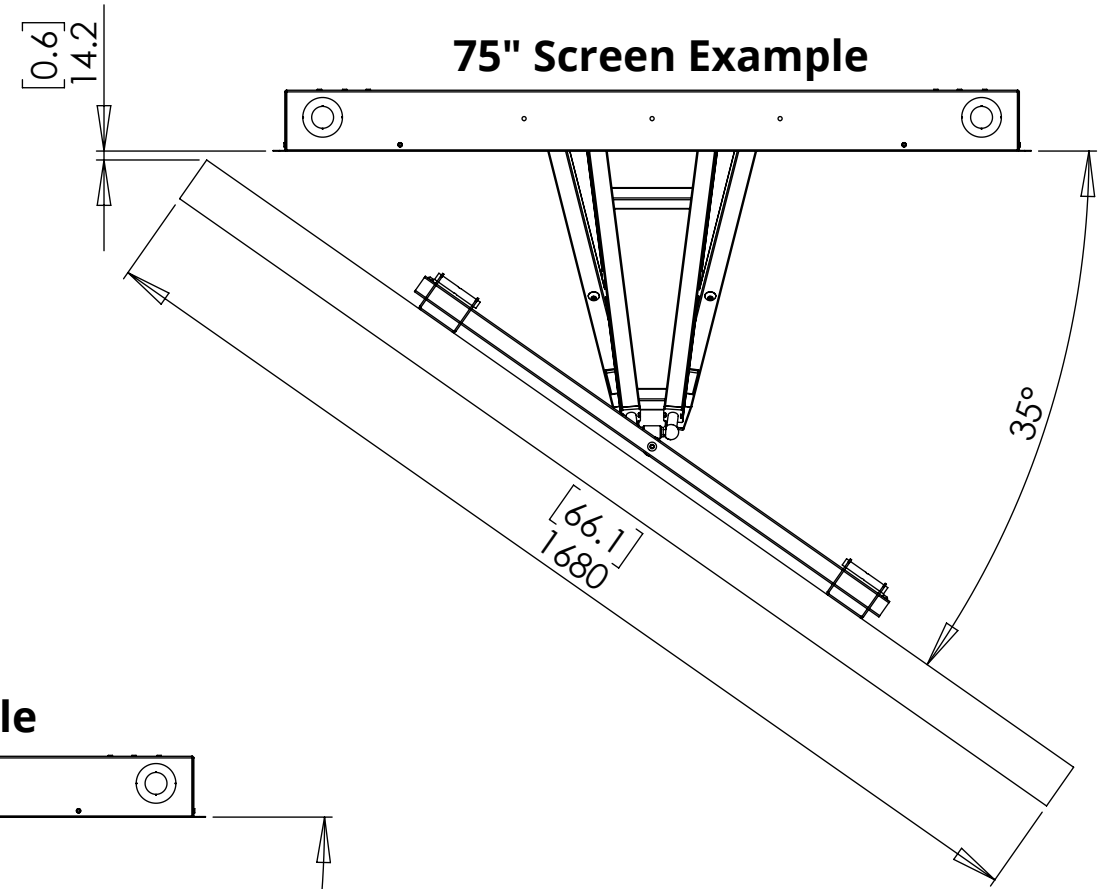
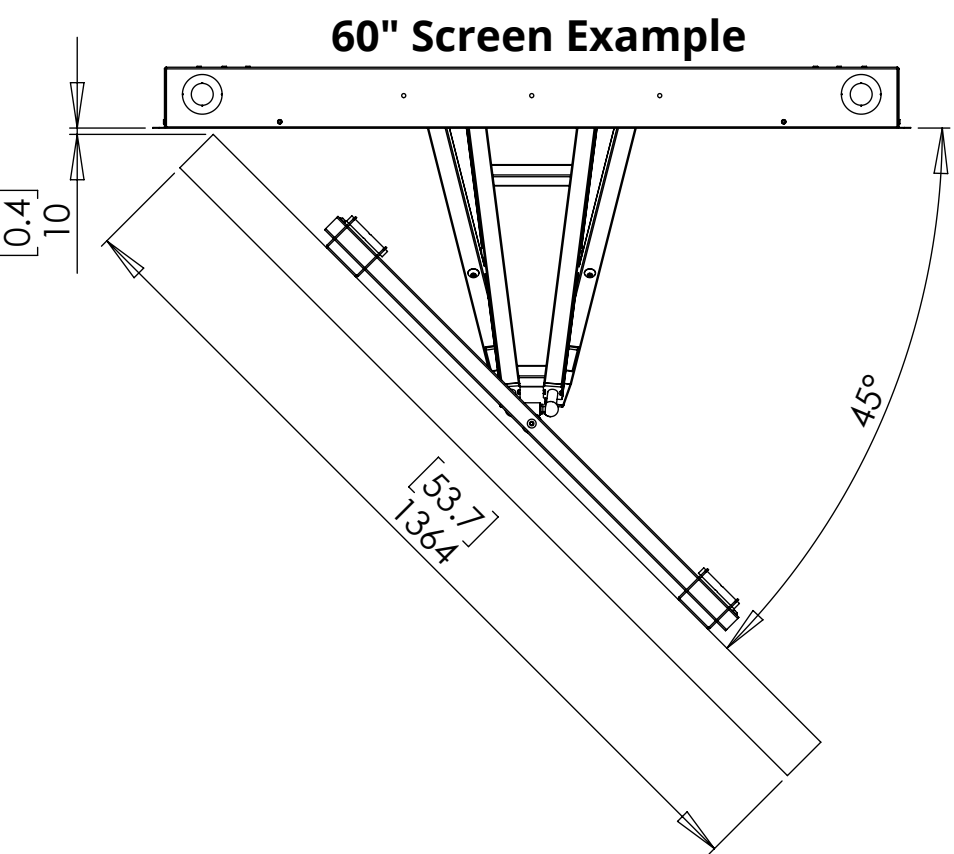

WB80

WALL BOX FOR PS80

EXPLODED VIEW

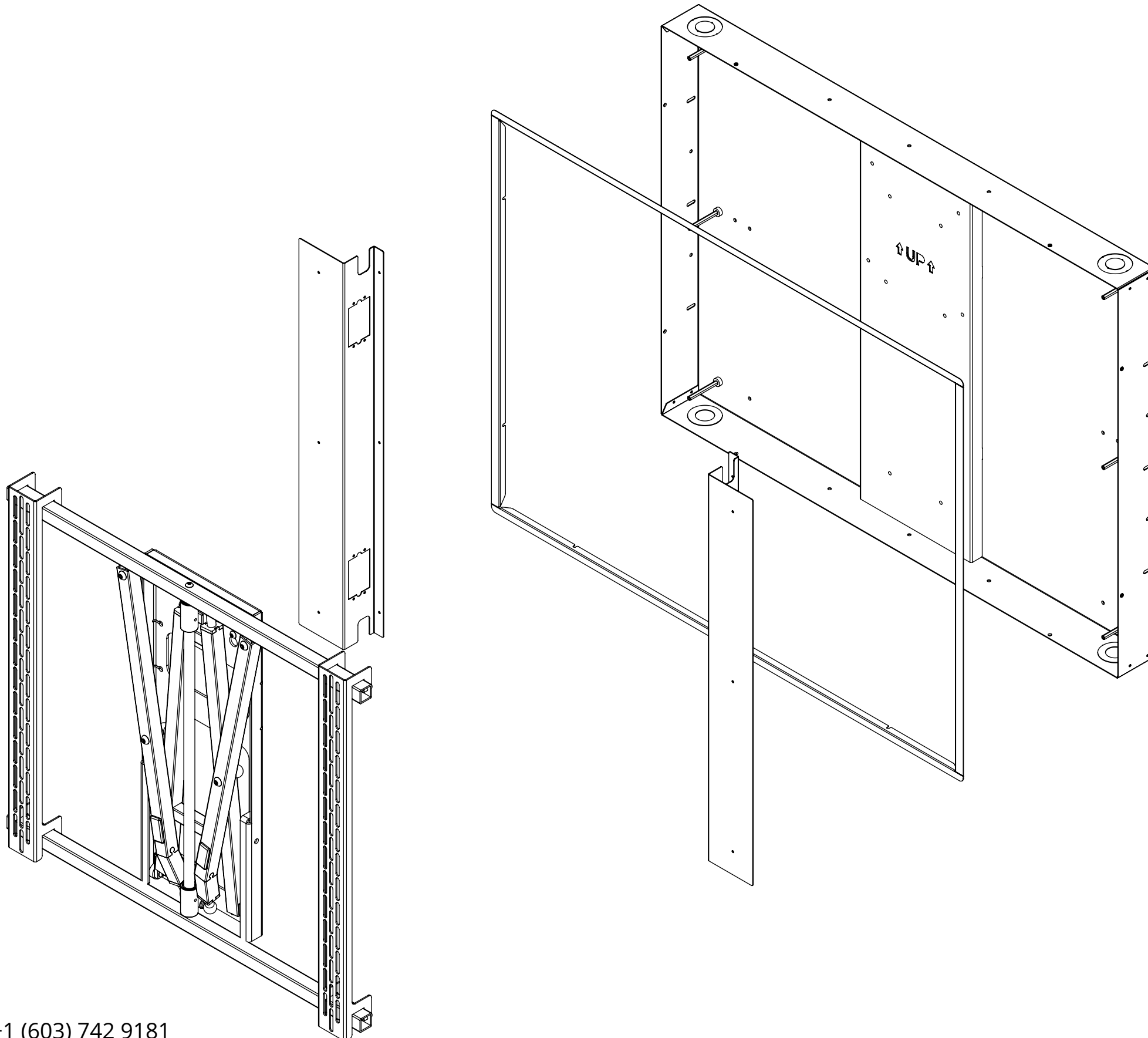

WB80 WALL BOX FOR PS80

WALL RECESS DIMENSIONS

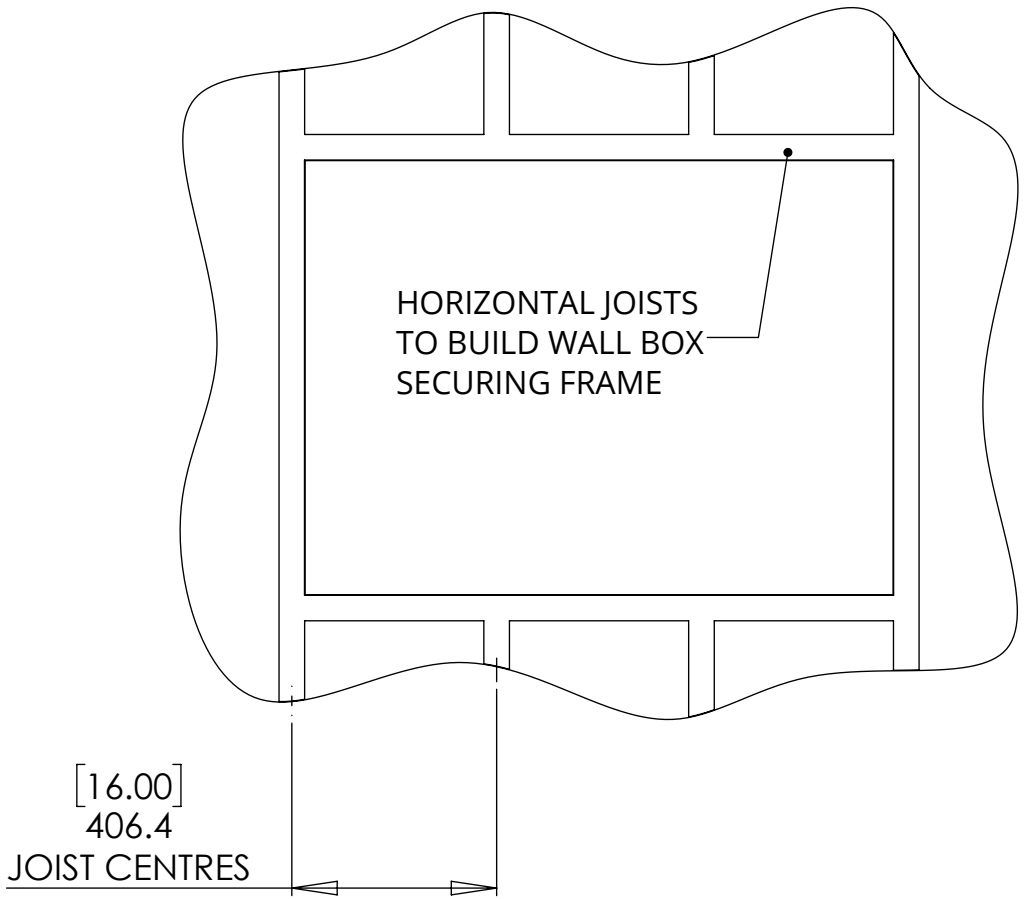

INSERT THE WALL BOX INTO THE VOID AS SHOWN THEN SECURE THROUGH THE SIDE FIXING HOLES

